

APPLICATION:

PRODUCT NAME:

DECK MOUNT POT FILLER W/VAC. BREAKER

JOB NAME:

_____ SPECIAL CONFIGURATION
(CHECK BASE MODEL AND OPTIONS)

QUANTITY:

ITEM NO.:

MODEL:

■ 5340

OPTIONS OR MODIFICATIONS:

- VANDAL RESISTANT KIT
- HANDLES (CROSS OR WRIST) CIRCLE STYLE
- OTHER _____

FEATURES:

- * 8" DECK
- * SWIVELING SEAT DISKS
- * HOT SIDE STEM - RIGHT HAND
- * COLD SIDE STEM - LEFT HAND
- * STAINLESS STEEL SEATS
- * STAINLESS STEEL SEAT SCREWS
- * STAINLESS STEEL HANDLE SCREWS

HOSE

- * 72" HEAT MASTER FDA NITRILE/ARAMID
- * NSF-51 (100 PSI W.P. @300° F) CONSTANT
- * RENEWABLE END FITTINGS & BUMPER
- * INLET - 360° SWIVEL VACUUM BREAKER
- * OUTLET - 360° SWIVEL SPOUT W/VINYL FINISH
- * 360° SWIVEL GOOSENECK
- * NONMARRING GOOSENECK
- * 360° SWIVEL ATMOSPHERIC VACUUM BREAKER

RECOMMENDED SETTINGS

- * 110°F AT 80 PSI

SYSTEM LIMITS

- * TEMP: 40°F MIN. TO 140°F MAX.
- * PRESSURE 200 PSI MAX. STATIC
- * 37 GPM AT 80 PSI

SHIPPING WEIGHT

- * 11.0 LBS

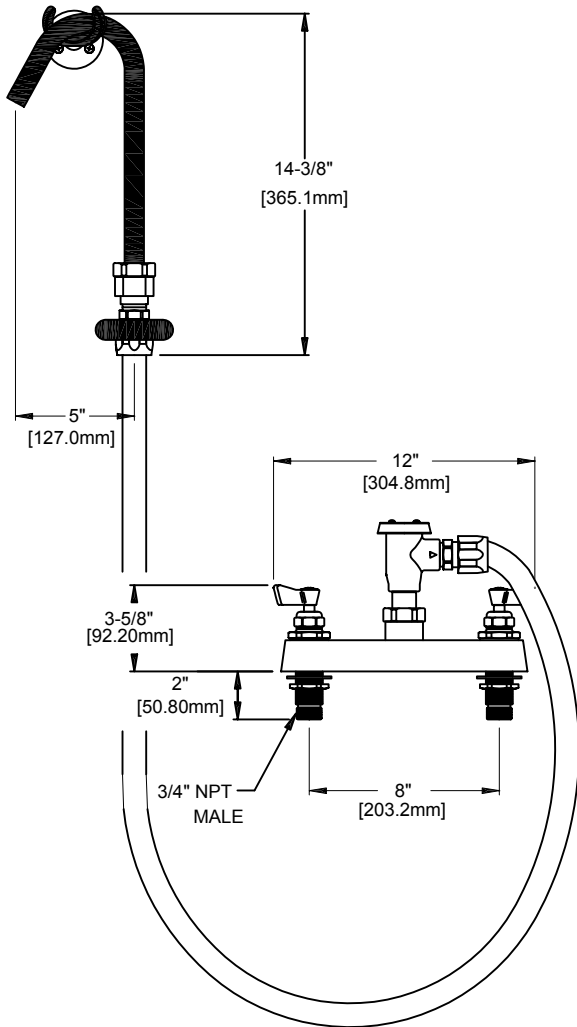

ROUGH-IN:

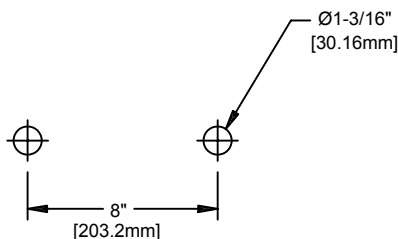

ANSI/A112.18.1M, ANSI/NSF 61.9

FISHER

FISHER MANUFACTURING COMPANY
TOLL FREE: 800-421-6162 - FAX: 800-832-8238
information@fisher-mfg.com - www.fisher-mfg.com